

Aeolus Series Internal Ground Set 50I-80I

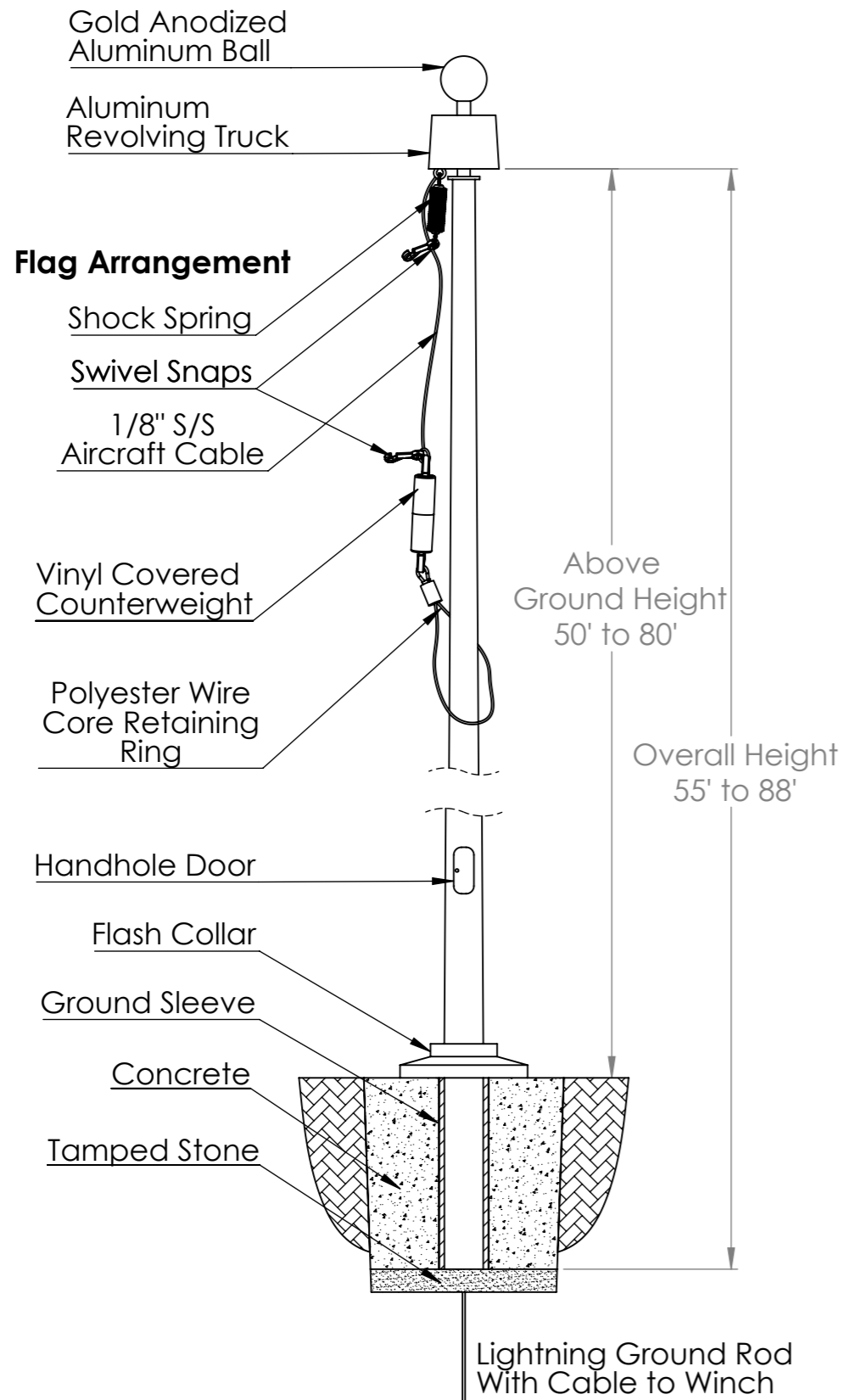

Internal Winch and Handhole Door

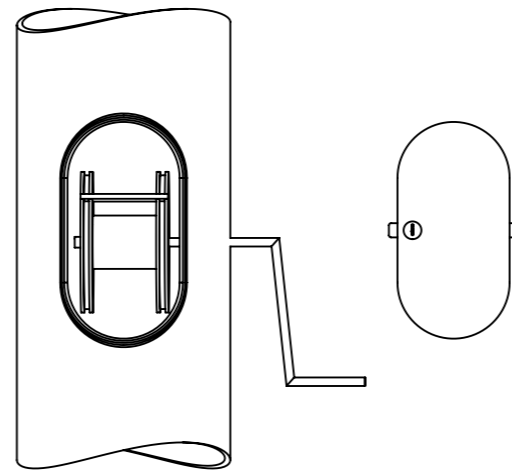

Aluminum Revolving Truck

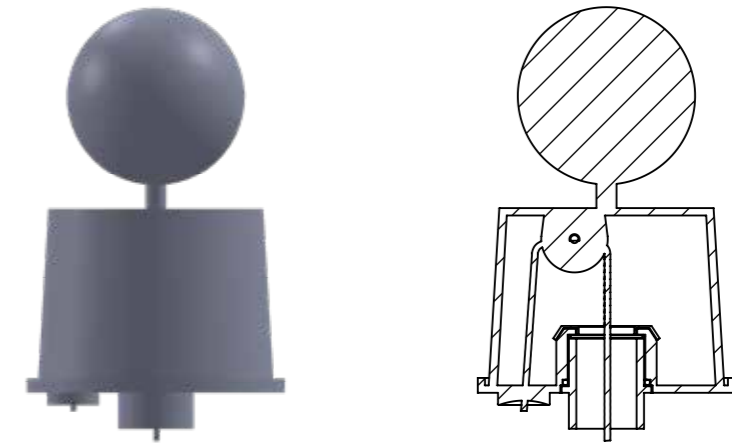

Specifications and Accessories

Model	50I	60I	70I	80I
Above Ground Height	50'	60'	70'	80'
Overall Height	55'	66'	77'	88'
Butt Diameter	10"	10.5"	16"	16.5"
Top Diameter	4.5"	4.5"	7"	7"
Pole Weight (lbs)	325	480	807	1108
Shipping Weight (lbs)	577	776	1336	1648
Ground Sleeve I.D.	14"	8"	21"	21"
Ground Sleeve Length	5'	6'	7'	8"
Ball Diameter	10"	10"	12"	12"
Halyard	S/S Cable	S/S Cable	S/S Cable	S/S Cable
Flash Collar	23"	23"	30"	30"
Truck	Rev-AL	Rev-AL	Rev-AL	Rev-AL
Snaps	S/S	S/S	S/S	S/S
Standard Flag Size	8'X12'	10'X15'	12'X18'	12'X18'

Specifications

Provide a Fiberglass Reinforced Composite (FRC) Ground set flagpole Model # **60I** as manufactured by PLP Composites, Fitzwilliam, NH 03447.

The flagpole shall have a mounting height of 60' and 6' below grade for an overall length of 66'.

The butt diameter shall be 10.5" and the top diameter 4.5". The pole weight shall be approximately 480 lbs. and a total shipping weight of 776 lbs.

The flagpole shall be manufactured of fiberglass woven roving and polyester resin with 75% of the reinforcing fibers oriented in the axial plane for maximum stiffness and 25% in the radial plane for required hoop strength. Load calculations shall be based on AASHTO and NAAMM standards with the pole designed with a two to one (2:1) safety factor for 125 mph winds, unflagged, with a 1.3 gust factor.

The flagpole shall have an Entasis taper and shall be void of vertical mold seams.

The flagpole shall be sanded smooth and coated with a high gloss Aliphatic Polyurea coating system which provides extended UV protection and weatherability.

Internal pole is to be equipped with a winch operating system. Not pre-installed at the factory, parts provided in fitting kit.

Standard colors include: White, Black, Bronze, Faux-Luminum, and Metallic Bronze



Aeolus Series - Model #60I	Standard Fittings:		Project:
60' Above Grade Height	10" Gold Anodized Ball	1/8" S/S Aircraft Cable	
66' Overall Height	Revolving Truck	23" Flash Collar	Location:
Top Diameter - 4.5"	1-10'x15' Flag Arrangement	Medium Retaining Ring	
Butt Diameter - 10.5"	Winch & Winch Handle	Large Counterweight	Date:
		6'x 14" Ground Sleeve	

PLP Composites

57 Creamery Road - PO Box 429, Fitzwilliam, NH 03447 - Phone: 800-262-6075 - www.plpcomp.com or www.zeusflagpoles.com - info@plpcomp.com